



Centrifugal Fan

Type: **DRAD 315-4.6SA**

Art.-No.: C10-31500



Curve:

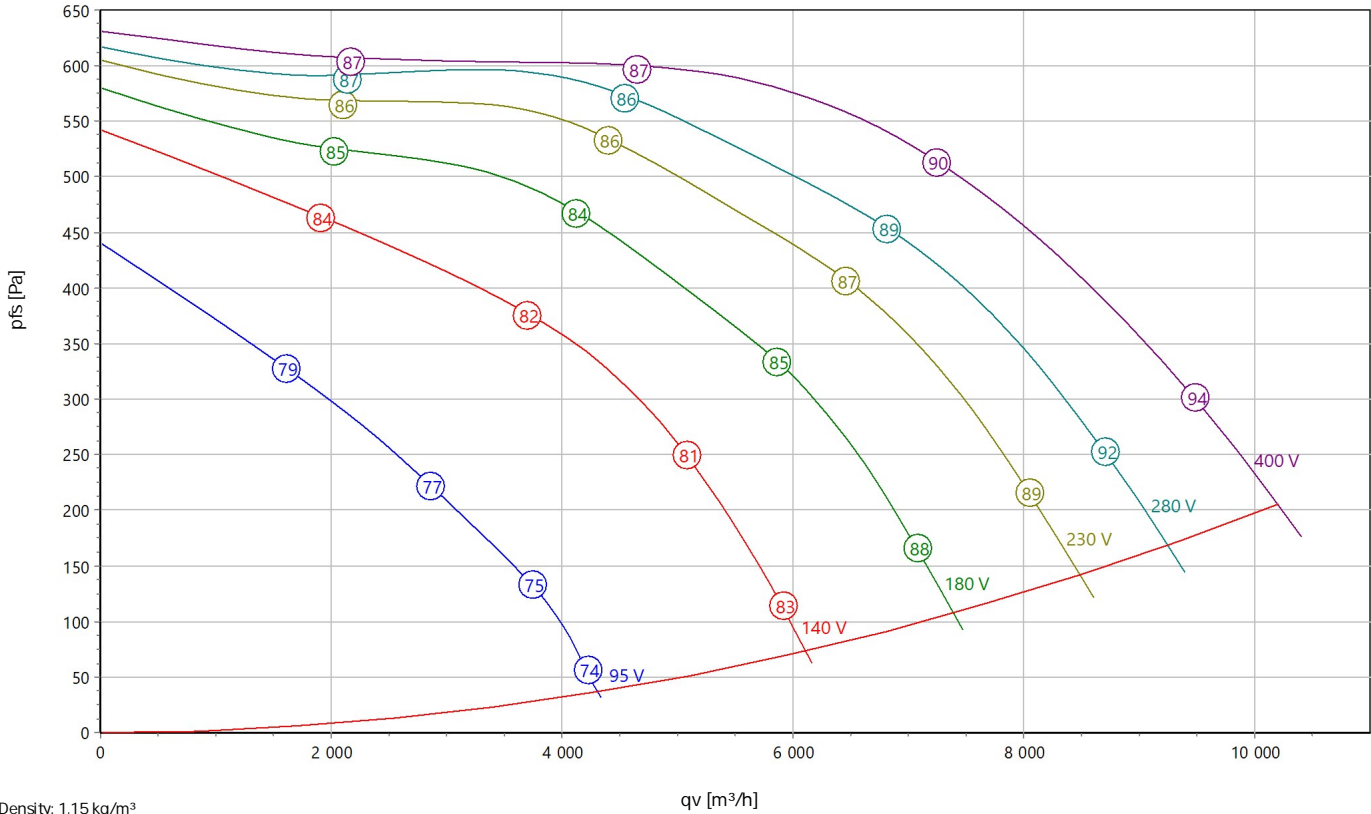

ErP-Data:

Type:	Lot11	
qv	6001	m ³ /h
pf	668	Pa
η _{e,tot}	45,6	%
P _e	2,44	kW
n	1436	r/min
N	49	

Nominal Data:

U [V]	f [Hz]	P _e [kW]	I _N [A]	n _N [r/min]	C [μF]	t _R [°C]	p _{fS,min} [Pa]	I _A / I _N	IP	m [kg]
400D	50	4,6	8,85	1370	-	40	210	4,3	IP 54	46

Sound Data:

Frequency		125Hz	250Hz	500Hz	1KHz	2KHz	4KHz	8KHz	Distances	1 m	4 m
LwA(B,in) [dB(A)]	-3	-21	-16	-13	-8	-7	-13	-19	LpA(B,in) [dB(A)]	-10	-20
LwA(B,out) [dB(A)]		-21	-13	-8	-4	-7	-8	-15	LpA(B,out) [dB(A)]	-7	-17



Centrifugal Fan

Type: **DRAD 315-4.6SA**

Art.-No.: C10-31500

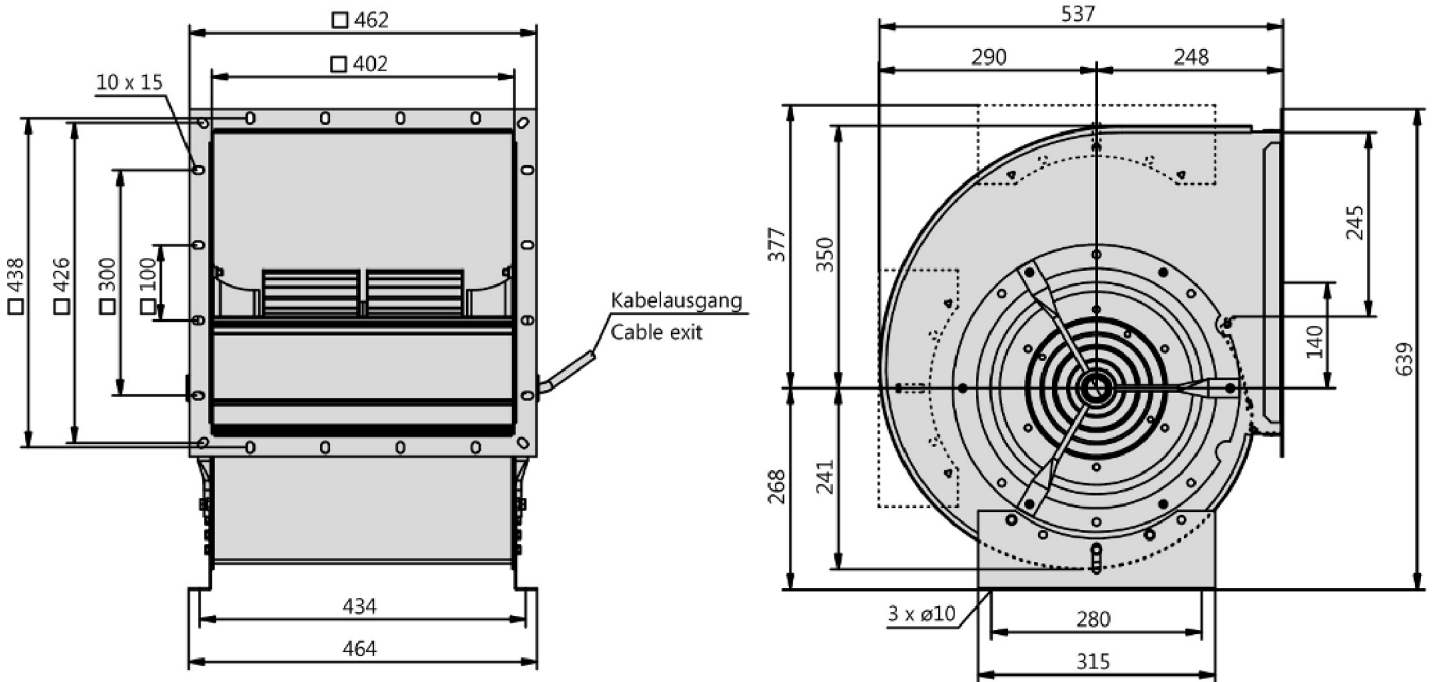

AC-Centrifugal Fan double inlet

in scroll casing with forward curved impeller

Double inlet impeller made of galvanized steel sheet with forward curved blades. Due to the high number of blades results in a sound optimized and at the same time compact design. Fluidic optimized scroll casing made from galvanised sheet metal. Double inlet. Stands respectively casing mountable in all 90° positions. Motorized Impeller statically and dynamically balanced according to DIN ISO 21940-11 with quality level G2.5. Voltage controllable AC external rotor motor. Maintenance free ball bearings, closed on both sides with long-term lubrication. Motor coated black and/or die casted aluminum. Standard configuration with cable. Motor protection is guaranteed by thermal contacts, which are inlaid into the motor windings. These contacts protect the motor from being overloaded through phase failure, too high medium temperature or locked rotor. Isolation Class F.

Fan complies with the guidelines required (Machinery-, EMC- and Low Voltage Directive) to comply with installation and conformity declaration as well as CE marking. Standard version with UL approval.

Nominal Data:

Voltage [U]

400 D V

Frequency [f]

50 Hz

Input power [P]

4,6 kW

Current [I]

8,85 A

Speed [n]

1370 r/min

Medium temperature [tR]

40 °C

Protection Mode

IP 54

Weight [m]

46 kg

Dimensions [L / W / H]

537 mm / 462 mm / 639 mm

Contact:

Rosenberg Ventilatoren GmbH

Maybachstraße 1

D - 74653 Künzelsau - Gaisbach

www.rosenberg-gmbh.com

Type:

DRAD 315-4.6SA

Article-No.:

C10-31500



Centrifugal Fan

Type: **DRAD 315-4.6SA**

Art.-No.: C10-31500



Drehstrommotor in Δ -Schaltung mit Thermostatschalter (TB).
Drehrichtungsänderung durch Vertauschen von 2 Phasen.

Three phase motor in delta connection with thermostatic switch (TB). Changing of rotation direction by interchanging of 2 phases.

Moteur triphasé branché en triangle avec interrupteur thermostatique (TB). Changement de sens de rotation par inversion de deux phases.

TK3-20004

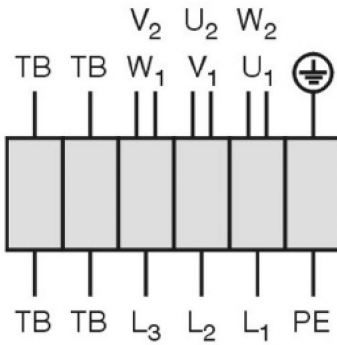

U ₁	braun / brown / brun
V ₁	blau / blue / bleu
W ₁	schwarz / black / noir
U ₂	rot / red / rouge
V ₂	grau / grey / gris
W ₂	orange / orange / orange
TB	weiß / white / blanc
PE	gelb-grün yellow-green jaune-vert

01.006