



Tube Fan

Type: **Z 160.3CA R2**

Art.-No.: F05-16013



**Curve:**

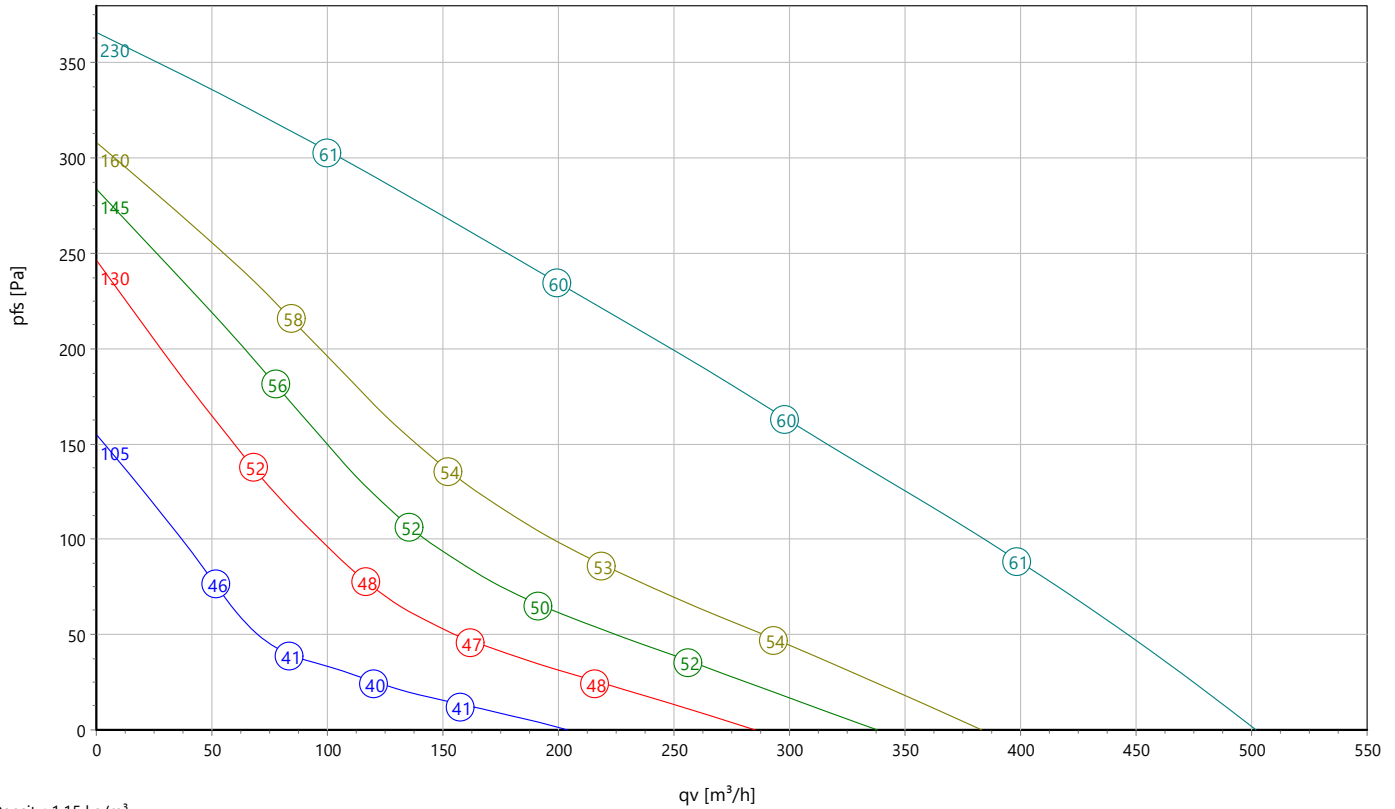

Density: 1,15 kg/m³

**ErP-Data:**

Type:	Lot6	
qv	266	m³/h
pfs	197	Pa
ηe,fs	24,7	%
Pe	0,06	kW
n	2474	r/min
N	42	

**Nominal Data:**

U [V]	f [Hz]	Pe [kW]	IN [A]	nN [r/min]	C [μF]	tr [°C]	k10 [m²s/h]	IA / IN	IP	m [kg]
1~230	50	0,06	0,26	2465	2	70	-	1,1	IP 44	14

**Sound Data:**

Frequency	Σ	125Hz	250Hz	500Hz	1KHz	2KHz	4KHz	8KHz	Distances	1 m	4 m
LwA(D,in) [dB(A)]		-12	-4	-9	-9	-9	-9	-14	LpA(D,in) [dB(A)]	-7	-17
LwA(D,out) [dB(A)]	6	-13	2	-1	-2	-2	-6	-14	LpA(D,out) [dB(A)]	-1	-11
LwA(D,cas) [dB(A)]	-11	-19	-13	-19	-26	-31	-38	-41	LpA(D,cas) [dB(A)]	-18	-28



Tube Fan

Type: **Z 160.3CA R2**

Art.-No.: F05-16013

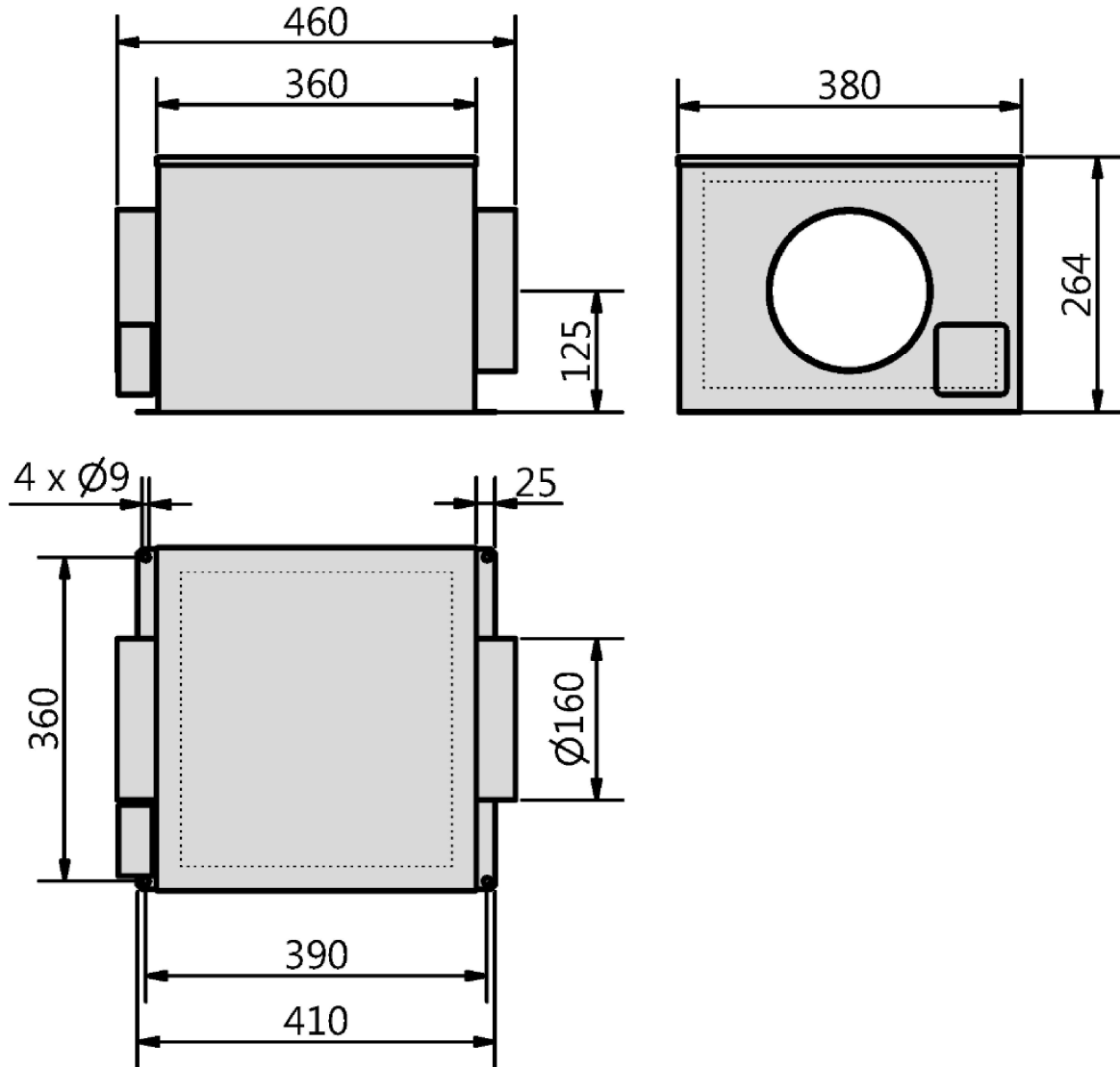

### Zerobox "REVOLUTION"

Tube fan with sound-insulated housing

The flat casing made of galvanized sheet steel as sound absorbing construction. The inlaid 40mm thick rockwool plates have a sound attenuating effect. The covering lid can easily be unscrewed to gain access for cleaning and maintenance. The motor is removable together with the impeller and spiral scroll. Inlet and outlet side with duct connection for standard round ducts. Mounting either with horizontal or vertical motor shaft. Impeller of the E-series (Revolution) made of black, UV-stabilized and long glass fibre reinforced Polypropylene (PP) with 7 backward curved, profiled blades and narrow efficiency optimized circumferential diffusor. Sound and weight optimized. Corrosion resistant and compact design. Air Flow orientated behaviour. Direct driven single phase AC motor with moisture protection. The motors have integrated motor protection (thermal contacts). Maintenance free ball bearings, closed on both sides, with long-term lubrication. Motorized Impeller statically and dynamically balanced according to DIN ISO 21940-11 with quality level G2.5. The electrical connection is mounted on the housing by a terminal box. Air volume control: possible by the use of an electronic speed controller or a step transformer (accessory).

Fan complies with the guidelines required (Machinery-, EMC- and Low Voltage Directive) to comply with installation and conformity declaration as well as CE marking.

#### Nominal Data:

Voltage [U]

1~230 V

Frequency [f]

50 Hz

Input power [P]

0,06 kW

Current [I]

0,26 A

Speed [n]

2465 r/min

Medium temperature [tR]

70 °C

Protection Mode

IP 44

Weight [m]

14 kg

Dimensions [L / W / H]

460 mm / 380 mm / 264 mm

#### Contact:

Rosenberg Ventilatoren GmbH

Maybachstraße 1

D - 74653 Künzelsau - Gaisbach

[www.rosenberg-gmbh.com](http://www.rosenberg-gmbh.com)

#### Type:

Z 160.3CA R2

#### Article-No.:

F05-16013



Tube Fan

Type: **Z 160.3CA R2**

Art.-No.: F05-16013



Einphasenwechselstrommotor mit Betriebskondensator und Thermostatschalter.  
Thermostatschalter intern mit der Wicklung in Reihe geschaltet.

**Single phase A.C. motor with operating capacitor and thermostatic switch.**  
**Thermostatic switch internal wired in series with windings.**

**Moteur monophasé avec condensateur permanent et interrupteur**  
**thermostatique en série avec le bobinage en cas de branchement**

TK3-20005

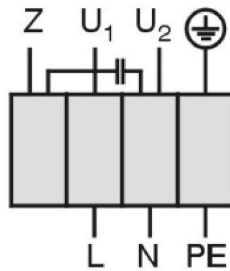

U<sub>1</sub> blau / blue / bleu  
 U<sub>2</sub> schwarz / black / noir  
 Z braun / brown / brun  
 PE gelb-grün  
 yellow-green  
 jaun-vert

01.009